

OMB10

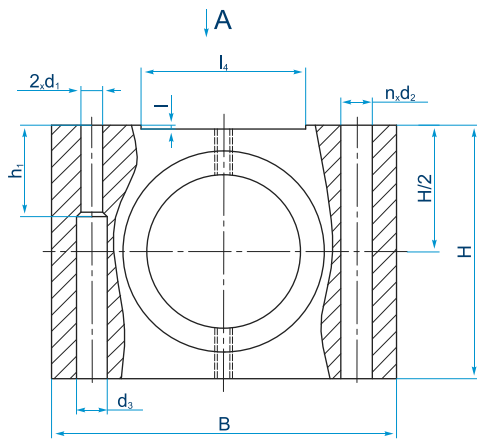

A (8×d₂)

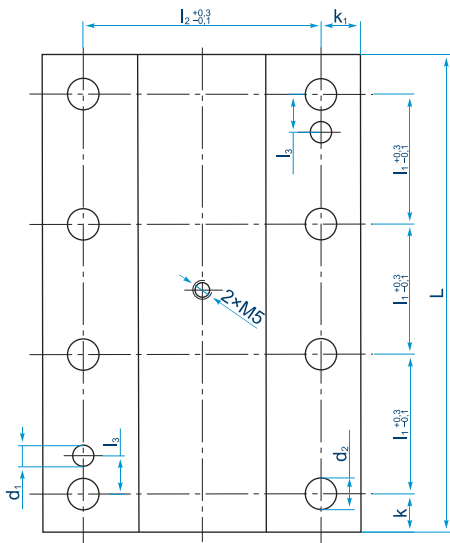

OMB15

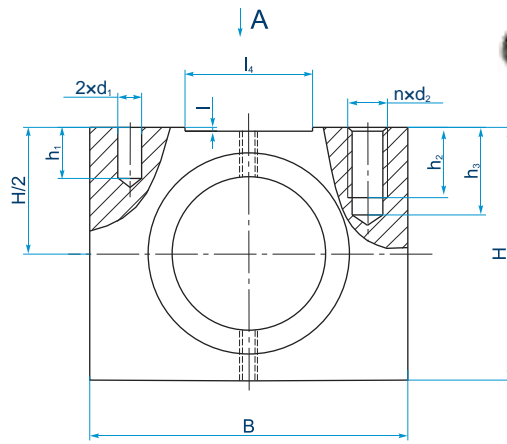

Натяг створений та зафіксований диференціальним зубчастим зачепленням гайок з корпусом.
Pre-loading is created and fixed by differential toothed engagement of nuts with housing.



A (6×d₂)

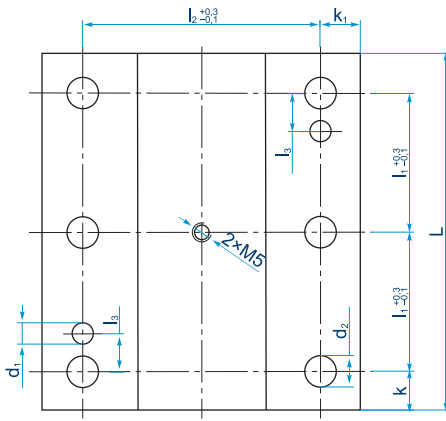

A (4×d₂)

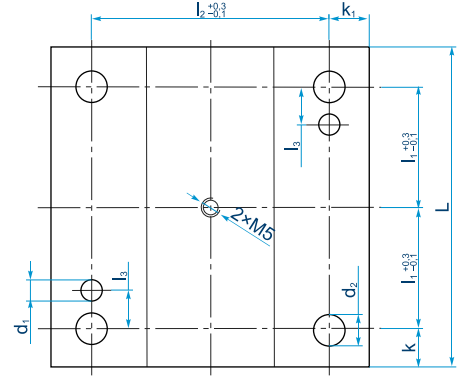

OMB10, OMB15										OMB10						OMB15								
d ₀ , mm	p, mm	i*, mm	H, mm	L, mm	l ₁ , mm	d ₁ , mm	h ₁ , mm	l ₃ , mm	n×d ₂	B, mm	l ₂ , mm	d ₂ , mm	d ₃ , mm	k, mm	k ₁ , mm	l ₄ , mm	B, mm	l ₂ , mm	d ₂ , mm	l ₄ , mm	k, mm	k ₁ , mm	h ₂ , mm	h ₃ , mm
25	5	3+3	50	80	44	7,8	16	20	4	66	50	9	9	18	8	30	60	45	M8	30	18	7,5	10	18
32	5	3+3	60	80	44	7,8	16	20	4	90	70	11	11	18	10	40	72	55	M10	38	18	8,5	13	22
40	5	3+3	72	80	44	7,8	16	20	4	100	76	13	13	18	12	50	85	66	M12	47	18	9,5	12	23
40	10	3+3	72	130	47	7,8	16	20	6	100	76	13	13	18	12	50	85	66	M12	47	18	9,5	12	23
50	5	3+3	84	80	44	9,8	20	20	4	110	86	13	13	18	12	60	90	70	M12	50	18	10	12	23
50	10	3+3	90	130	47	9,8	20	20	6	114	90	13	13	18	12	60	90	70	M12	50	18	10	12	23
63	10	3+3	108	130	47	9,8	20	24	6	144	112	17	17	18	16	70	114	90	M16	66	18	12	21	32
80	10	3+3	126	130	45	12	24	24	6	150	123	17	17	20	14	90	120	95	M16	70	15	13	17	28
80	20	3+3	132	240	64	12	24	30	8	182	140	22	17	24	21	100	145	115	M20	85	24	15	23	35
100	10	3+3	150	130	92	12	24	30	4	212	160	26	17	19	26	110	168	135	M24	102	19	17	30	45
100	20	3+3	156	240	64	12	24	30	8	220	168	26	17	24	26	110	168	135	M24	102	24	17	30	45

*i — кількість робочих контурів гайки.

Виготовлення і 3+3 обговорюється додатково. Конструкція не передбачає встановлення очисників різьблення.

*i — nut working contour quantity.

Custom i 3+3 screws are available upon request. Design does not allow wiper installation.